



Regupol®

TECHNICAL DATA SHEET

REGUPOL® 6010SH HIGH PERFORMANCE SCREED ISOLATION

PRODUCT DESCRIPTION

A recycled crumb product, Regupol® 6010SH has been specifically developed for heavy load bearing areas where acoustic performance is critical. A sustainable and high performing screed isolation solution, Regupol® 6010SH delivers the greatest load bearing capacity in the CMS Danskin Acoustics underscreed range.

APPLICATIONS

Designed for a wide range of high performance isolation applications, Regupol® 6010SH is particularly suited to heavily loaded areas in:

- Luxury apartments
- Penthouses
- Hotels
- Schools
- Hospitals
- Libraries
- Retail
- Music studios



BENEFITS

- Independent Laboratory and Field Test Data available upon request showing compliance with Approved Document E Building Regulations (England & Wales) and Section H of the Scottish Building Regulations
- Excellent impact and airborne performance
- Offers long term performance without collapse or “bottoming” out under high point loads
- Resistant to ageing and deformation
- Quick and easy to install
- High quality and exact material thickness guaranteed
- Mildew and moisture proof
- Zero global warming potential (GWP) and zero ozone depletion potential (ODP)
- Product manufactured using Recycled Materials and 100% recyclable

WWW.CMSDANSKIN.CO.UK

CMSDANSKIN
ACOUSTICS

PHYSICAL INFORMATION

Sheet length	1.25m
Sheet width	10m
Material thickness	10mm & 15mm nominal

TECHNICAL INFORMATION

Mean value of dynamic stiffness	28.8MN/m ³ (DIN EN 29052-1)
Density	595kg/m ³
Tensile strength (DIN 53571)	approx 0.4N/mm ²
Thermal conductivity	approx 0.14W/mK
Elongation at break	approx 70%
Maximum load bearing capacity	10,000kg/m ² (100kN/m ²)
Temperature resistance	-40°C to +110°C
ΔL_w (impact improvement)	30dB

INSTALLATION SERVICE

In addition to supply of this product, CMS Danskin Acoustics offers a competitively-priced installation service anywhere in the UK. Use of our service ensures that installation is performed to the highest standards by tradesmen fully experienced in the specialist skills of fitting acoustic materials correctly.

Please contact your local CMS Danskin Acoustics for further details.

INSTALLATION

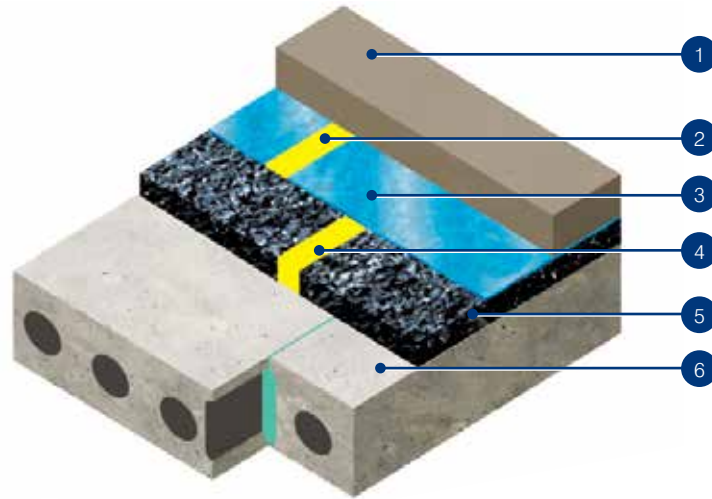

Joint Detail

Perimeter Detail

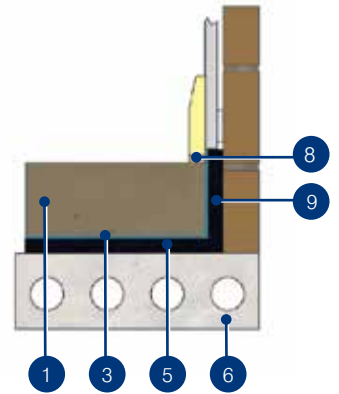
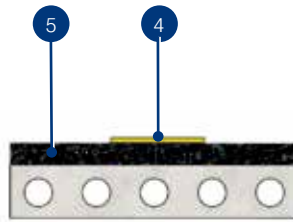
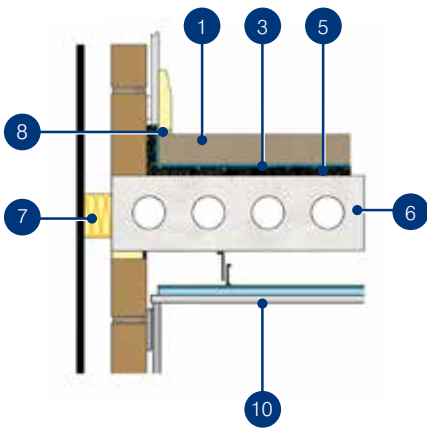

All illustrations for example purposes only

1. 65mm sand cement screed
2. Taped joint*
3. Min.500 gauge polythene
4. Hi-tack tape or similar approved
5. Regupol® 6010SH 10mm or 15mm layer
6. Pre-cast or beam and block floor, minimum 300kg/m²
7. Acoustic cavity closer

8. Acoustic sealant
9. Perimeter edge strip
10. Ceiling (construction type will vary)

*DPM overlap to be minimum 100mm

CMS DANSKIN ACOUSTICS

Scotland Office: Tel: **01698 356000** Fax: **01698 372222**
1 Netherton Road, Wishaw, ML2 0EQ

Central/Southern Office: Tel: **01925 577711** Fax: **01925 577733**
Unit 2 Lyncastle Road, Appleton, Warrington, WA4 4SN

Email: info@cmsdanskin.co.uk Website: www.cmsdanskin.co.uk

IMPORTANT: Directions for use are given for guidance only and are not intended to form part of any contract. They should be varied or adapted to suit your particular materials or conditions of use. Goods supplied by the company are made to approved standards from the highest quality raw materials but no warranty or guarantee is given as to their suitability for any particular purpose or application, and no liability is accepted for any loss or damage arising directly or indirectly from the use of the Company's products irrespective of any information given to us as to intended use of such products. It is therefore recommended that prospective users should test a sample of this product under their own conditions to satisfy themselves that the product is suitable for the purpose intended.

CMSDANSKIN
ACOUSTICS